

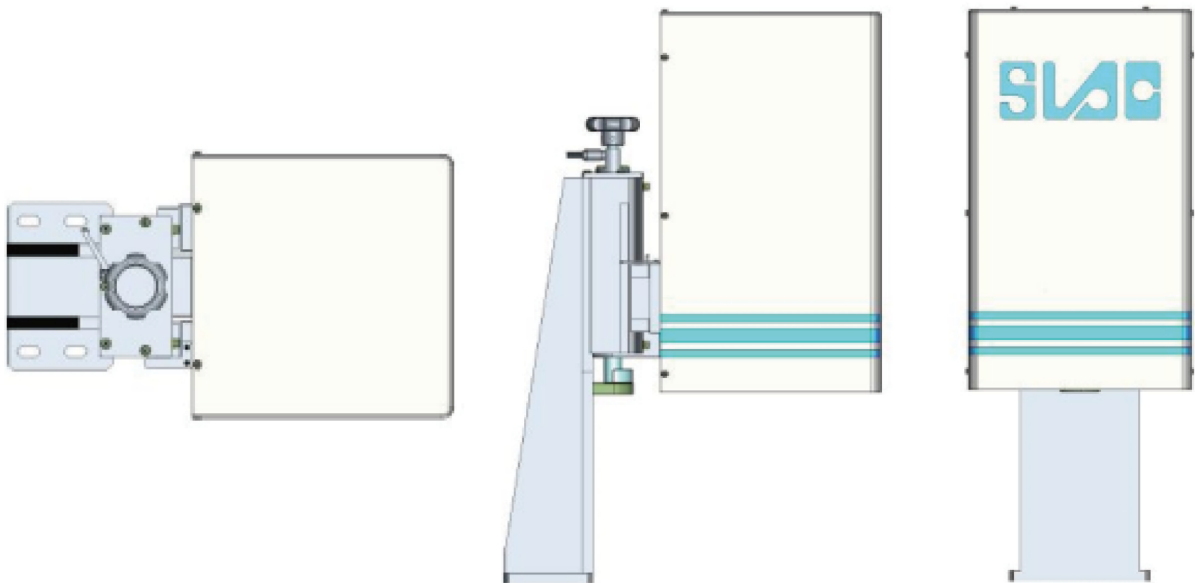

DIGITAL PRINTING QUALITY INSPECTION SYSTEM

Digital Printing Quality Inspection System uses a high-resolution line-array camera to take images of the products to be inspected online. The image is analyzed by the self-developed image processing software, the detection results are displayed in real time, and the high-speed elimination device is used to ensure the defective products are discharged accurately. It has the advantages of real-time, efficient and accurate.



SUZHOU SLAC PRECISION EQUIPMENT CO.,LTD

No.1028,Sunwu Road,Xukou Town,Wuzhong District,Suzhou,Jiangsu Province,China

Tel: 0086-512-66930111

Fax: 0086-512-66248543

E-mail: slac@slac.com.cn

Http: www.slac.com.cn



Main feature

- ◆ Easy to operate
- ◆ High Speed and High accuracy
- ◆ High reliability
- ◆ Customizations to products
- ◆ Support online 24 hours

Applications

- ◆ Cylindrical Products
- ◆ Roll Plastic Film
- ◆ Pull-Up Material
- ◆ Others

Test items

- ◆ Color Shifts
- ◆ Ink Blobs
- ◆ Loss Color
- ◆ Over Printed
- ◆ Pattern Blur
- ◆ so on

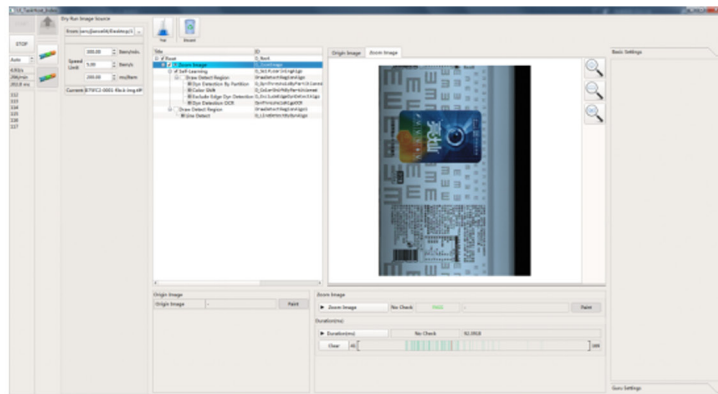

Detecting interface



Sample

SUZHOU SLAC PRECISION EQUIPMENT CO.,LTD

No.1028,Sunwu Road,Xukou Town,Wuzhong District,Suzhou,Jiangsu Province,China

Tel: 0086-512-66930111

Fax: 0086-512-66248543

E-mail: slac@slac.com.cn

Http: www.slac.com.cn